



Hoardfast uPVC is a **clean and quick to install, modular, internal screening system**, used part-height free-standing with a range of support and stability options, or fixed floor-to-ceiling.

Create a temporary **screen to contain dust and noise** or **create internal site rooms** during fit out, refurbishment and construction projects. Supplied ready to install, Hoardfast uPVC comes in a range of heights and is available for purchase or hire.



Hire or Purchase



Express Delivery

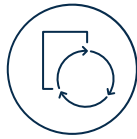

Reconfigure, Relocate and Re-use



Smart Appearance



Quick, Clean, Easy Installation



Recyclable and Sustainable



## Features and Benefits

Modular ready to install system	<ul style="list-style-type: none"> <li>• Quick, clean, easy installation saves valuable set up time on site compared to traditional methods</li> <li>• Easy to configure as required</li> </ul>
Sustainable product that can be hired, reused and recycled	<ul style="list-style-type: none"> <li>• Pay for and use the product only for the time you need</li> <li>• Save money by reusing the same panels and components on phased or multiple projects</li> <li>• Reduced overall environmental impact for your project</li> </ul>
Graded panel options	<ul style="list-style-type: none"> <li>• Choose a grade and price of panel to suit your project</li> </ul>
Lightweight panel	<ul style="list-style-type: none"> <li>• Easy to move around site</li> </ul>
1.12m, 2.25m, 2.7m, 3m (free-standing) / 4m, 5m (floor-to-ceiling)	<ul style="list-style-type: none"> <li>• Create quick floor-to-ceiling or free-standing partitions</li> <li>• Easy to cut and configure as required</li> </ul>
Express delivery is available from large UK stock	<ul style="list-style-type: none"> <li>• Get items on site quickly to prevent delays</li> </ul>
Easy fit single and double doors/ironmongery (with Digi lock)	<ul style="list-style-type: none"> <li>• Create restricted access to construction sites or site offices and welfare spaces</li> </ul>

## Installation

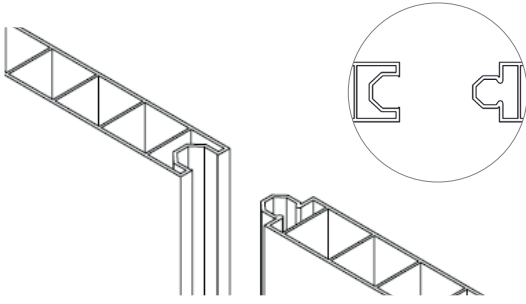

Panels are connected by knocking together the tongue and groove. Corner posts and T-sections are also available.

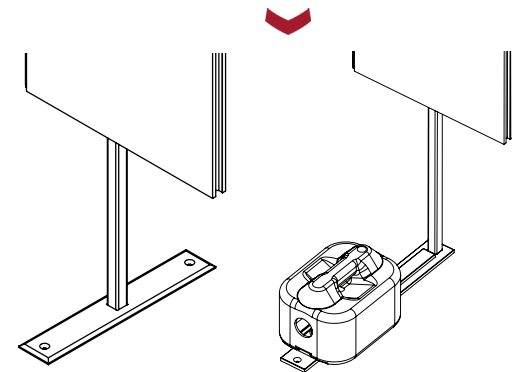

Free-Standing Equal

Free-Standing Offset

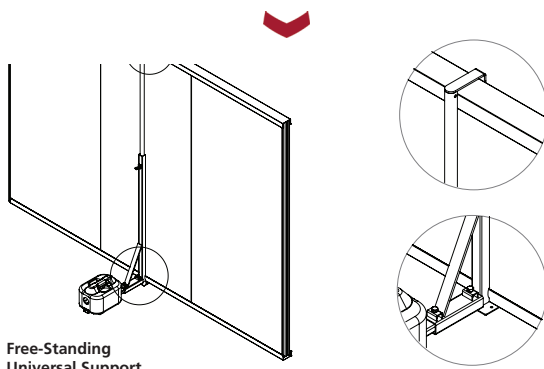

Free-Standing Universal Support

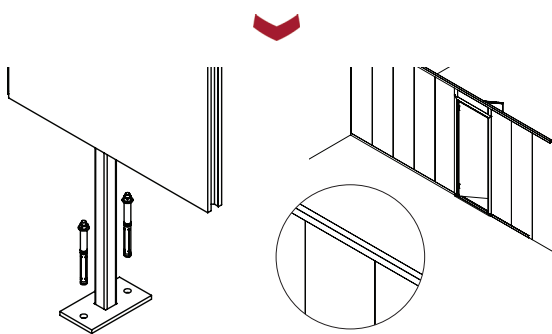

Free-Standing Bolt Down

Floor-to-Ceiling U-Channel Top & Bottom

Hoardfast Standard uPVC works with a range of free-standing stability options or install floor-to-ceiling supplied u-channels.

\* This fact sheet is for illustrative purposes only and based on the latest information at the time of print. Installation methods may vary depending on specific project requirements. Westgate Global reserve the right to make changes at any time without notice.

J222-WG-PFS-HF-UPVC-070324 © Westgate Global Ltd

## Technical Specifications

Material Composite	85% recycled PVC, 15% Virgin PVC, grey hollow fluted internal and solid white micro ridged external face
Connection Method	Tongue and groove
Panel Fire Rating	BS476 Part 7 Class 1 (Spread of Flame) and EN13501-1 C s3 d0 (35mm only)
Acoustic Properties	Up to 27dB reduction in sound (insulation)
Thermal Insulation (U-Value)	2.95 W/m <sup>2</sup> K (35mm profile) 2.43 W/m <sup>2</sup> K (50mm profile) *Theoretically calculated
Standard Panel Heights	1.12m, 2.25m, 2.7m, 3m (free-standing) / 4m, 5m (floor-to-ceiling)
Panel Width	0.5m
Panel Thickness	35mm (up to 2.7m), 50mm (3m-5m)
Support Options	Floor-to-ceiling; supplied with u-channel fixings or Free-standing; equal, offset, universal, bolt down

All standard stock is dispatched using an express delivery service and hire and purchase options are available for both panels and supports. Optional extras include; vision panels and doors.

