



Hoardfast Soundscreen is a **quick-to-install, modular, internal hoarding system**, designed to reduce the impacts of noise created from construction or refurbishment work.

Perforated to one side, the panel **absorbs noise and provides an average of 34dB sound reduction**. 50mm thick and mineral wool filled, it is manufactured from materials with limited combustibility.



Certified 34dB Sound Reduction

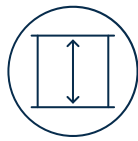

Floor-to-ceiling or Free-standing



Express Delivery



Quick-to-install Modular System



Range of Panel Heights



Reusable and Relocatable

## Features and Benefits

Modular ready to install system	<ul style="list-style-type: none"> <li>• Quick, clean, easy installation saves time and money on site setup</li> <li>• Easy to configure as required</li> </ul>
Panel is perforated to one side	<ul style="list-style-type: none"> <li>• Produce a certified minimum 34dB* sound reduction.</li> </ul>
System can be reused	<ul style="list-style-type: none"> <li>• Install and demount the system multiple times giving medium and long-term savings</li> <li>• Reduces waste and environmental impact on construction projects</li> </ul>
2.7m, 4m (panel cutting service also available)	<ul style="list-style-type: none"> <li>• Create quick floor-to-ceiling or free-standing partitions</li> <li>• Configure as required</li> </ul>
Express delivery service; fast and reliable from large UK stock	<ul style="list-style-type: none"> <li>• Get items on site quickly to prevent delays</li> </ul>
Easy fit single and double doors (with Digi lock)	<ul style="list-style-type: none"> <li>• Create restricted access to construction sites or site offices and welfare spaces</li> </ul>

\*System installed floor-to-ceiling. Free-standing system may not meet 34dB sound reduction

## Installation

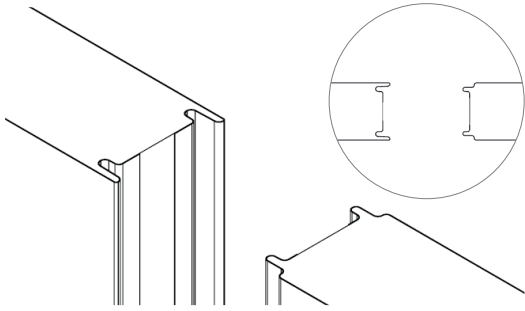

Panels join with a tongue and groove system. Corner posts and T-sections for perpendicular walls also available.

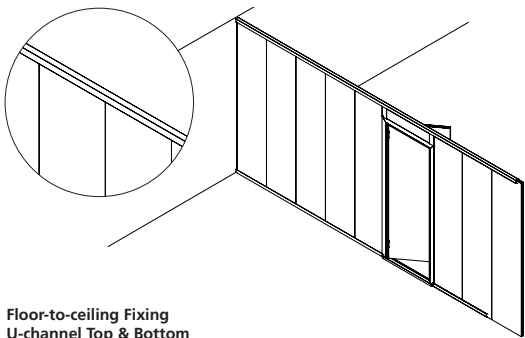

Floor-to-ceiling Fixing  
U-channel Top & Bottom

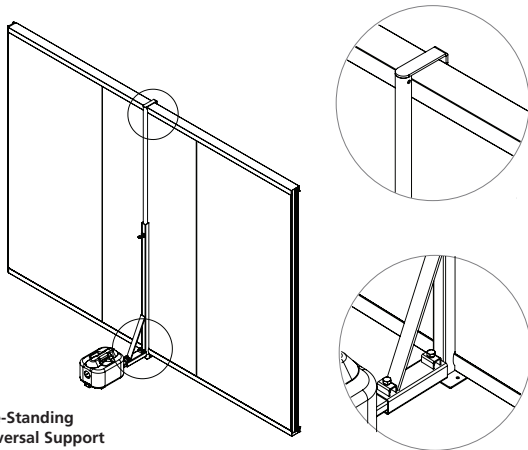

Free-Standing  
Universal Support

Soundscreen can be installed floor-to-ceiling using supplied u-channels or for a free-standing system choose our universal support, which can hold 1 - 6 16kg weights.

This fact sheet is for illustrative purposes only and based on the latest information at the time of print. Installation methods may vary depending on specific project requirements. Westgate Global reserve the right to make changes at any time without notice.

J222-WG-PFS-HF-SS-070324 © Westgate Global Ltd

## Technical Specifications

Material Composite	White steel faced mineral wool filled (perforated to construction side)
Connection Method	Tongue and groove push fit
Panel Fire Rating	Tested and certified to EN13501-1 A2 s1 do (limited combustibility)
Acoustic Properties	RW = 34dB
Thermal Insulation (U-Value)	0.75 W/m <sup>2</sup> K
Standard Panel Heights	2.7m, 4m (panels can also be cut to order on request)
Panel Width	1m
Panel Thickness	50mm
Panel Weight	14.5 kg/m <sup>2</sup>

A range of panel heights are available and panels can be installed floor-to-ceiling or free-standing using Westgate's unique universal support. The Soundscreen panel is available to purchase only, supports are available to hire.

