



Hoardfast Firescreen is a **quick-to-install, modular, internal screening system**. Available in a range of heights, the steel faced panel is tested to **EN 13501-2:2008 A2 s1 d0 and EI60 fire resistance**, and also offers excellent acoustic and thermal benefits.

Offering a **three-in-one solution** for multistory new build construction projects, the panel offers a **60 minute fire rating**, **can be used for external applications when a weathering panel is required**, and **create internal site office and welfare facilities**.



Fire Rated Panel

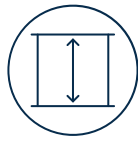

Floor-To-Ceiling or Free-Standing



Express Delivery



Quick-To-Install Modular System



Range of Panel Heights



Reusable and Relocatable

Features and Benefits

Modular ready to install system	<ul style="list-style-type: none"> • Quick, clean, easy installation saves time and money on site set up • Easy to configure as required
Fire rated panel - EN 13501-2:2008 A2 s1 d0 fire class rating and EI60 fire resistance	<ul style="list-style-type: none"> • Simple and effective floor-to-ceiling 60 minute fire protection (Note: fire rating does not apply when a free-standing system is used)
Panels provide additional acoustic properties and thermal insulation	<ul style="list-style-type: none"> • Reduce the impacts of construction noise on the surrounding areas • Create quieter internal site office and welfare spaces • Allow for dry area to be created for internal site rooms
Sustainable product that can be reused	<ul style="list-style-type: none"> • Install and demount the product multiple times giving medium and long-term savings • Reduces waste and environmental impact on construction projects
2.25m, 2.7m, 3.1m (free-standing) / 3.5m, 4.0m, 4.5m (floor-to-ceiling)	<ul style="list-style-type: none"> • Create quick floor-to-ceiling or free-standing partitions • Configure as required
Express delivery is available	<ul style="list-style-type: none"> • Get items on site quickly to prevent delays
Easy fit single and double doors / ironmongery (with Digi lock)	<ul style="list-style-type: none"> • Create restricted access to construction sites or site offices and welfare spaces
Three-in-one solution (60 minute fire rating, weatherproofing and internal site offices)	<ul style="list-style-type: none"> • Used to create internal site office and welfare facilities during multistory new build construction projects • Can be used for external applications, when weathering panels are required

*Free-standing systems do not offer the same level of fire protection.

Installation

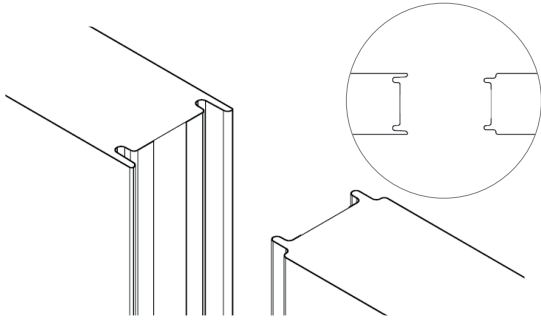

Panels join with tongue and groove system. Corner posts and T-sections for perpendicular walls also available.

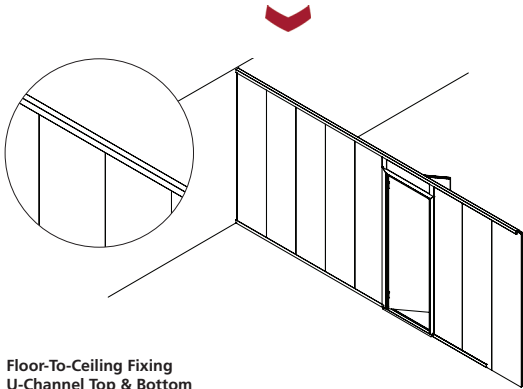

Floor-To-Ceiling Fixing
U-Channel Top & Bottom

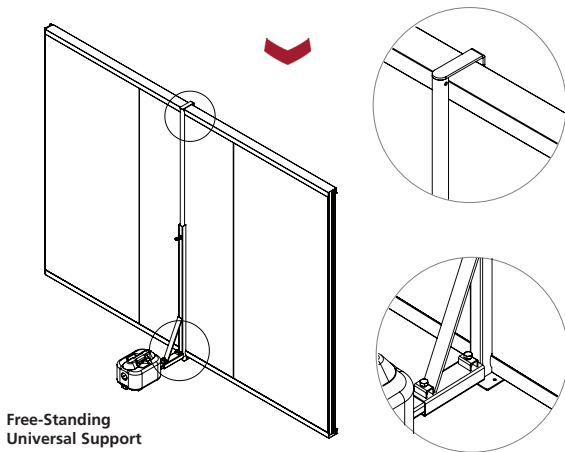

Free-Standing
Universal Support

Firescreen can be installed floor-to-ceiling using supplied u-channels or for a free-standing system choose our universal support, which can hold 1 - 6 16kg weights.

Technical Specifications

Material Composite	White steel faced mineral wool filled
Panel Colour	RAL9010-Pure White
Connection Method	Tongue and groove push fit
Panel Fire Rating	EN 13501-2:2008 A2 s1 d0 fire class rating and EI60 fire resistance
Thermal Insulation (U-Value)	0.5 W/m ² K
Standard Panel Heights	2.25m, 2.7m, 3.1m (free-standing) / 3.5m, 4.0m, 4.5m (floor-to-ceiling)
Panel Width	1m
Panel Thickness	80mm
Panel Weight	17.9 kg/m ²
Support Options	Floor-to-ceiling; supplied with u-channel fixings or Free-standing; universal support

Bespoke design available, for panel heights above 4.5m subject to survey and risk assessment.

Panels available to purchase only, supports available to hire. 90 minute and 120 minute fire ratings also available, subject to survey and risk assessment. Available for purchase on express delivery.



This fact sheet is for illustrative purposes only and based on the latest information at the time of print. Installation methods may vary depending on specific project requirements. Westgate Global reserve the right to make changes at any time without notice.

J222-WG-PFS-HF-FS-070324 © Westgate Global Ltd