

Flexiwall®

industrial partitioning



Flexiwall is a **unique floor-to-ceiling partition** wall that offers multiple benefits over traditional partitioning methods and is **particularly effective in tall buildings**.

Manufactured from a heavy duty fire rated material, Flexiwall is **quicker** and **cleaner to install** and can even be reconfigured, removed or relocated should business needs evolve.



Fire Rated
Material Options
Available



Customised to
Meet Business
Needs

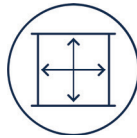

Floor to Ceiling;
Any Height and
Length



No Mess, Quick/Easy
Installation



Minimal Floor
Space Required



Easily Reconfigure,
Relocate or Remove

Features and Benefits

Heavy duty but light-weight material, can be manufactured to any height and length (subject to survey)	<ul style="list-style-type: none"> No restrictions to where the solution can be used Install on mezzanine floors with no concerns for additional weight loading
Easily fits around existing penetrations	<ul style="list-style-type: none"> Reduced project costs as no need to relocate services Creates an over 99% dust tight seal
Takes up only 50mm of floor space once installed	<ul style="list-style-type: none"> Can be installed between racking Maximises available floor space when creating new areas within existing space
Panels joined with unique v-overlap system	<ul style="list-style-type: none"> Creates an over 99% dust tight seal Panels can be easily replaced in sections Include fast action doors or access panels/openings
Fire rated materials	<ul style="list-style-type: none"> Create fire rated partition walls that fulfil both health and safety and insurance requirements
Translucent material options available	<ul style="list-style-type: none"> Reduce costs associated with new lighting requirements as material allows natural light transit
Incorporate brand colours and logos	<ul style="list-style-type: none"> Improves the environment for employees and visitors
Quick and clean to install	<ul style="list-style-type: none"> Reduced impact on existing production and operation schedules
Easily reconfigure, remove or relocate walls without damage	<ul style="list-style-type: none"> Adapt to unforeseen or unpredictable future business changes Works well in rented premises

Installation

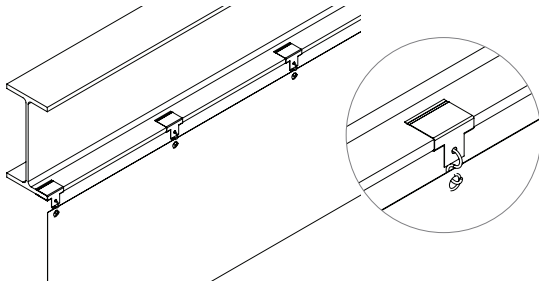

Panels are suspended using existing steelwork, clips and s-hooks.

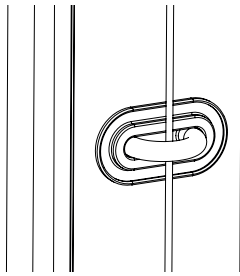
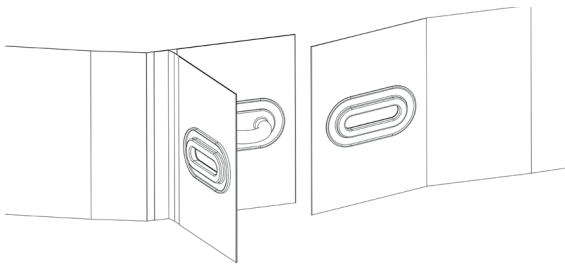

Panels are joined together using our unique v-overlap system.

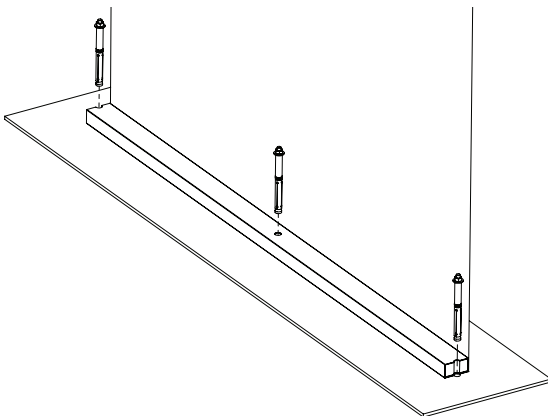

Panels are tensioned and secured using battens fixed to the floor.

This fact sheet is for illustrative purposes only and based on the latest information at the time of print. Installation methods may vary depending on specific project requirements. Westgate Global reserve the right to make changes at any time without notice.

J188-WG-PFS-FW-270224 © Westgate Global Ltd

Technical Specifications

Material Composite	Main product is polyester reinforced fire-retardant fabric with PVC coatings. We also supply a non-combustible woven glass fabric with PU coating <small>(*range of base fabric and coatings depending on your requirements)</small>
Material Weight	between 340gsm-1300gsm
Tensile Strength	between 340N-4000N / 50mm
Tear Strength	between 80N-850N
Material Fire Rating	BS 5867:2008 Part 2 Type A & B, Warrington Certifire TS62 & TS63, EN13501-1 A2s1d0, EN13501-1 Bs2d0, EN13501-1 Cs2d0 <small>(*subject to material specification, all fire ratings supplied at quote stage)</small>
Operating Temperature	between -40 / +500 degree centigrade <small>(*dependent on fabric type)</small>

Flexiwall can be easily designed to fit any size and shape of building and easily installs around existing ducts and pipework. Also available for external applications. Bespoke solutions are designed and installed by our experienced Westgate team.

